

A. LINEAR BOOTH - *(MAX HEIGHT 8')

Linear Booths have only one side exposed to an aisle and are generally arranged in a series along a straight line. They are also called "in-line" booths.

Dimensions

For purposes of consistency and ease of layout and/or reconfiguration, floor plan design in increments of ten feet (10') has become the de facto standard in the United States.

Therefore, unless constricted by space or other limitations, Linear Booths are most commonly ten feet (10') wide and ten feet (10') deep, i.e., 10'x10'. A maximum backwall height limitation of eight feet (8') is generally specified.

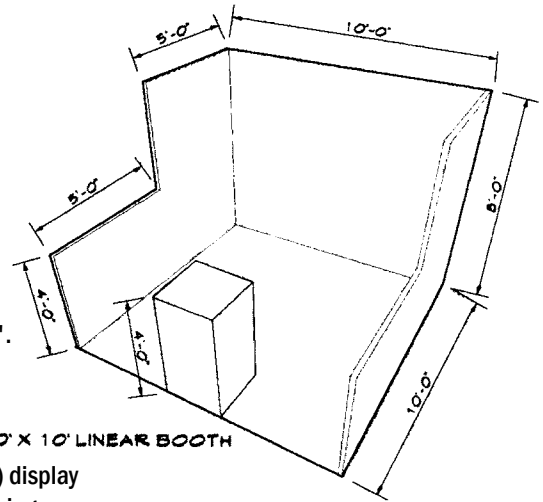

10' X 10' LINEAR BOOTH

Use of Space

Regardless of the number of Linear Booths utilized, (e.g., 10'x20', 10'x30', 10'x40', etc.) display materials should be arranged in such a manner so as not to obstruct sight lines of neighboring exhibitors. *The maximum height of eight feet (8') is allowed only in the rear half of the booth space, with a four-foot (4') height restriction imposed on all materials in the remaining space forward to the aisle. (Note: When three or more Linear Booths are used in combination as a single exhibit space, the four foot (4') height limitation is applied only to that portion of exhibit space which is within ten feet (10') of an adjoining booth.)

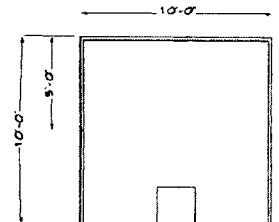

Plan

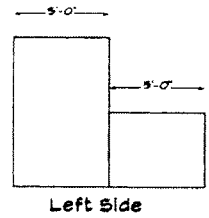

Left Side

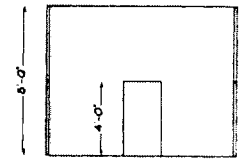

Front

B. CORNER BOOTH- *(MAX HEIGHT 8')

A Corner Booth is a Linear Booth exposed to aisles on two sides. All other guidelines for Linear Booths apply.

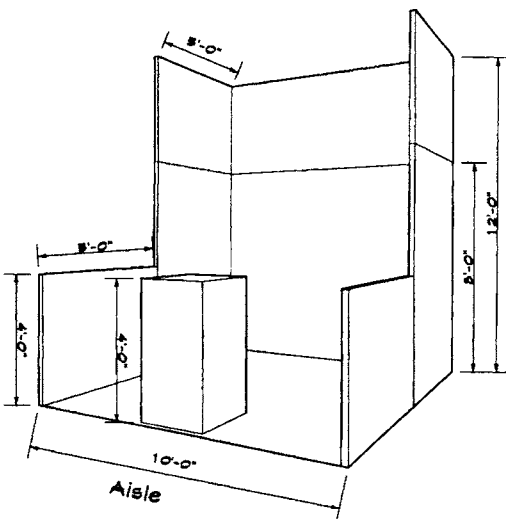

C. PERIMETER BOOTH

A Perimeter Booth is simply a Linear Booth that backs to a wall of the exhibit facility rather than to another exhibit.

Dimensions and Use of Space

All guidelines for Linear Booths apply to Perimeter Booths except that the typical maximum backwall height is twelve feet (12').

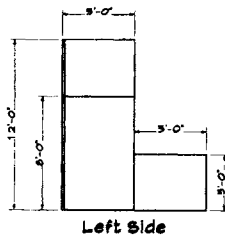

Left Side

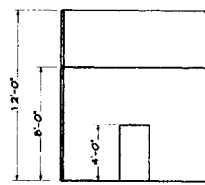

Front

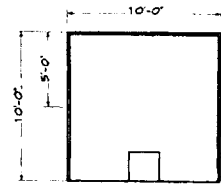

Plan

F. ISLAND BOOTH

An Island Booth is any size booth exposed to aisles on all four sides.

Dimensions

An Island Booth is typically 20'x 20' or larger, although it may be configured differently.

Use of Space

The entire cubic content of the space may be used up to the maximum allowable height, which is usually eighteen feet (18'), including signage.

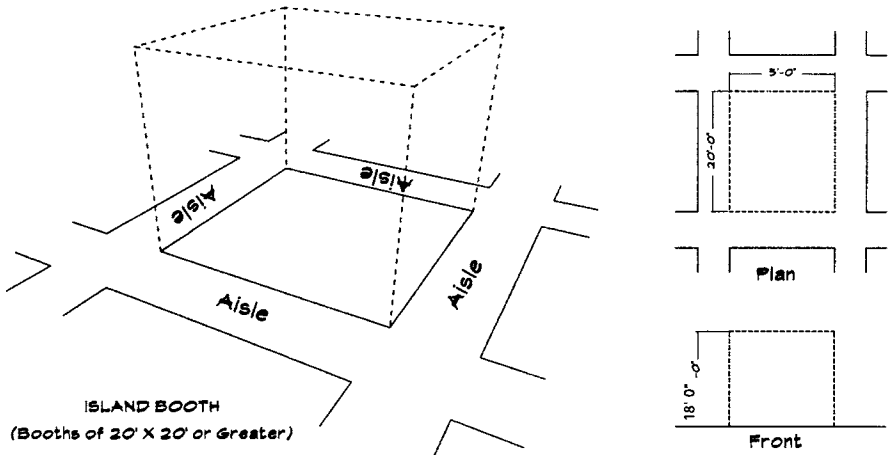

IMPORTANT NOTE: Exhibitors are urged by Show Management NOT to construct a display in such a manner so as to obstruct ALL sight lines of neighboring exhibitors.

a. **ARRANGEMENT OF DISPLAYS.** Exhibitor's displays must be contained completely within the specified boundaries of the booth space, including their height, in compliance with the International Association of Exposition Managers "Guidelines for Display Rules and Regulations" (as provided at www.ThePoolSpaShow.com), notwithstanding these guidelines no portion of said display may extend into the aisle nor into any adjoining booth or other area outside the perimeters of the booth or, in the judgment of NESPA, unreasonably restrict the view of another Exhibitor's display. Exhibitors that contract for Island displays are encouraged to provide Show Management with a layout of their booth display during the planning stages to determine if there is any question/concern by management regarding booth layout unreasonably restricting the view of neighboring exhibitors. Show Management has the authority to have exhibitors remove portions of their booth that "unreasonably" restrict line of site for neighboring exhibitors or areas of the main Show Entrance. Exhibitor's displays must provide sufficient standing or seating area within said perimeters to accommodate the booth attendants as well as any anticipated stationary audiences which the display is designed to attract.

(This guideline (regulation) deviates from the IAEM revised 2000 Update published Guidelines.)